



Technology Solutions

# TEK-COR 1100A

## Coriolis Mass Flowmeter



FLOW



[www.tek-trol.com](http://www.tek-trol.com)

Flow | Level | Temperature | Pressure | Valves | Analyzers | Accessories | TekValSys

## Introduction

There can often be more than one type of fluid used in your process, each with different properties. Your process and product quality completely depend on the accuracy with which you measure each of these fluids. Our range of Coriolis mass flowmeters are designed to suit your need to measure almost any fluid across any application. Built on the Coriolis principle, these meters measure the mass of the fluids directly, rather than volume and hence they do not require compensations for factors such as temperature and pressure which impact volume and accuracy of measurement.

## Measuring Principle

The Coriolis measuring principle refers to the effect that a moving mass has on a body in a rotating frame of reference. The moving mass exerts an apparent force on the body, causing a deformation. This force is called the Coriolis force. It does not act directly on the body, but on the motion of the body. This principle is used in Coriolis flowmeters.

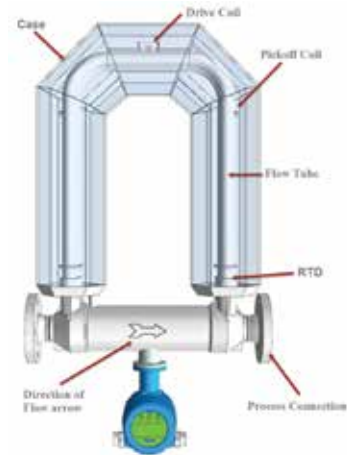

U-Shaped Coriolis Flowmeter

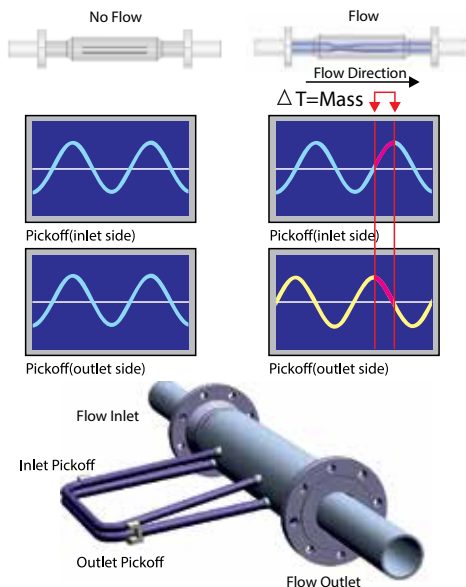

A diagram showing phase shift

## Operation

A Coriolis flowmeter consists of two parallel tubes that are made to oscillate using a magnet. These oscillations are recorded by sensors fitted at the inlet and outlet of each tube. In a no-flow state, the oscillations are synchronised, since there is no mass exerting any force on the tubes. On the other hand, any fluid, gas flowing through the tubes generates Coriolis forces, causing the tubes to twist in proportion to the mass flow rate of the medium.

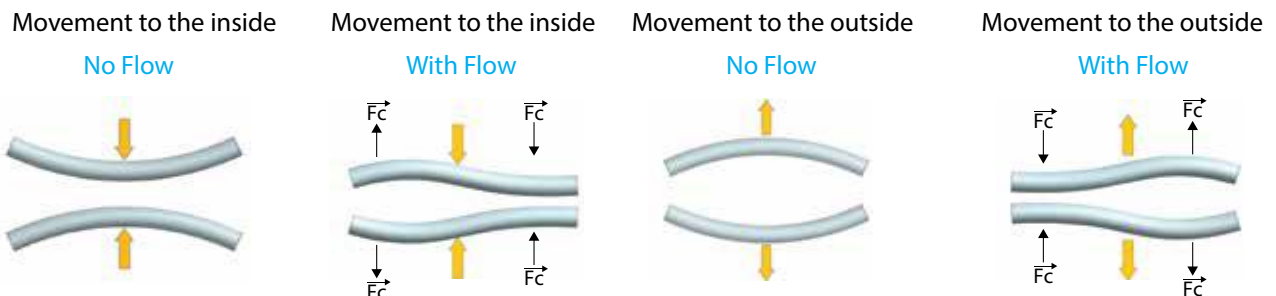

Diagram showing the movement of the flow sensors

## Tek-Cor 1100A Series Coriolis Flowmeter

The Tek-Cor 1100A Series Coriolis Flowmeters are available in the following three configurations:



U-Shaped sensor (Size 1 ½" to 8")

- ***U-Shaped***

These flowmeters are comprised of two tubes that are arranged in the shape of the letter 'U', a magnet and coil assembly, and sensors at the inlet and outlet of the tubes. Coriolis forces exerted by the flow medium are used to determine the mass flow rate and density of the medium.

- ***Micro-bend Shaped***

These flowmeters are comprised of two U-Shaped tubes in a casing with a considerably smaller radius than conventional U-Shaped Coriolis flowmeters. The smaller radius ensures a more compact instrument with significantly lower pressure differential values compared to other flowmeters.



Micro-bend Shaped sensor (Size ½" to 8")

- ***Triangle Shaped***

The Triangular flowmeter is the most compact in our range of Coriolis mass flowmeters, designed specifically to provide optimum performance in low-flow applications. It is comprised of a single flow tube which is considerably smaller in size than the conventional U-Shaped tube.



Triangle Shaped Sensor (Size ½" to 1")

## Tek-Cor 1100A Transmitter

The Tek-Cor 1100A transmitter is a high-performing transmitter that uses a micro-processor and offers zero calibration, adjustable pulse outputs, an RS485, and a HART communication protocol. It is highly stable and accurate, as well as easy to install and operate. It requires low maintenance which keeps your process downtime to a minimum and covers the cost of ownership over the long term.



Tek-Cor 1100A Transmitter

## Benefits

- Suitable for aggressive and contaminated media
- Measurement and display of percent water-cut for oil or water mixtures
- High rotation frequency and well-balanced measuring tubes
- Higher Sampling and Digital Filtering
- Shorter response time
- No moving parts
- Can be used in extremely harsh conditions
- High accuracy for measuring mass flow, density, temperature, and volume flow
- OLED with 2 line indication
- Measurement of net oil
- Density accuracy now had been updated to 0.001 g/cm<sup>3</sup>

## Application

- Used to measure steady uniform flow of common viscous fluid, non-Newtonian fluid, slurry containing some solid components, and liquids containing some trace of gases
- Suitable for the bulk measurement of products like syrup, molasses, and raw chemicals

## Dimensional Drawings

### Outline Dimension for Triangle Shaped

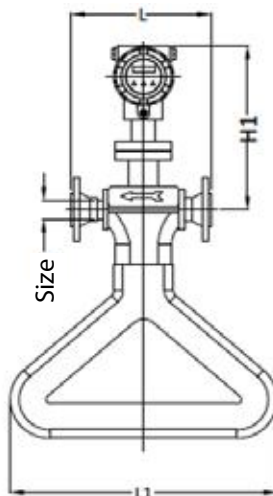

Triangle Shaped Sensor (Size ½" to 1")

Size	L		L1	H	H1	
	≤300# (4 MPa)	≥600# (6.3 MPa)			Integrated	Remote
½" (0.04 ft)	7.08" (0.59 ft)	7.63" (0.63 ft)	13.77" (1.14 ft)	11.41" (0.95 ft)	10.23" (0.85 ft)	7.48" (0.62 ft)
1" (0.08 ft)	7.87" (0.65 ft)	7.96" (0.81 ft)	18.03" (1.50 ft)	15.74" (1.31 ft)	11.02" (0.91 ft)	8.26" (0.68 ft)

### Outline Dimensions for U-Shaped

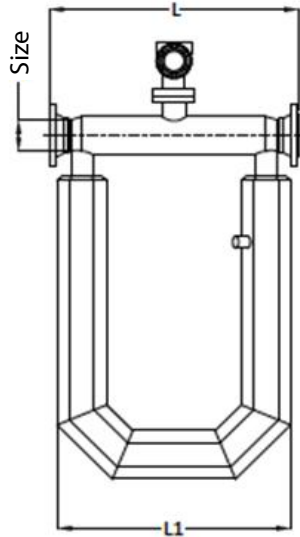

U-Shaped sensor (Size 1 ½" to 8")

Size	L		L1	H	H1	
	≤300# (4 MPa)	≥600# (6.3 MPa)			Integrated	Remote
1½" (0.13 ft)	20.47" (1.70 ft)	21.53" (1.79 ft)	18.5" (1.54 ft)	25.98" (2.16 ft)	11.02" (0.91 ft)	8.26" (0.68 ft)
2" (0.16 ft)	21.96" (1.83 ft)	23.14" (1.92 ft)	21.65" (1.80 ft)	27.95" (2.32 ft)	11.41" (0.95 ft)	8.66" (0.72 ft)
3" (0.26 ft)	30.70" (2.55 ft)	31.81" (2.65 ft)	27.95" (2.32 ft)	40.94" (3.41 ft)	12.59" (1.04 ft)	9.84" (0.82 ft)
4" (0.32 ft)	36.22" (3.01 ft)	37.32" (3.11 ft)	33.85" (2.82 ft)	44.88" (3.74 ft)	13.77" (1.14 ft)	11.02" (0.91 ft)
6" (0.49 ft)	43.30" (3.60 ft)	44.88" (3.74 ft)	41.33" (3.44 ft)	59.84" (4.98 ft)	14.96" (1.24 ft)	12.20" (1.01 ft)
8" (0.65 ft)	53.70" (4.47 ft)	55.51" (4.62 ft)	45.66" (3.80 ft)	65.15" (5.42 ft)	16.53" (1.37 ft)	13.77" (1.14 ft)

## Outline Dimension of Micro-bend Shaped

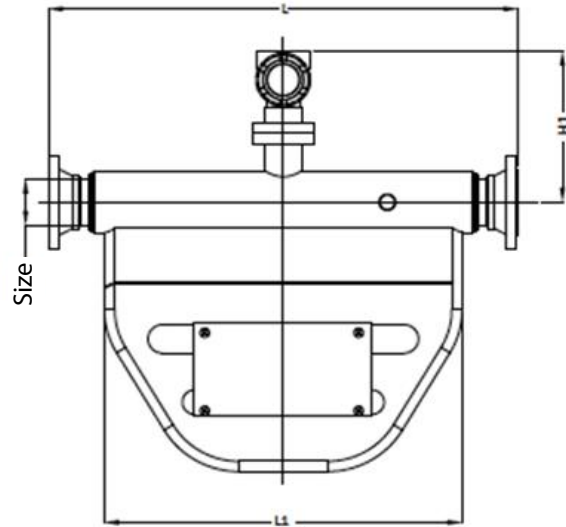

Micro-bend Shaped Sensor (Size ½" to 8")

Size	L		L1	H	H1	
	≤300# (4 MPa)	≥600# (6.3 MPa)			Integrated	Remote
½" (0.04 ft)	15.74" (1.31 ft)	16.29" (1.35 ft)	11.02" (0.91 ft)	7.24" (0.60 ft)	11.41" (0.95 ft)	8.66" (0.72 ft)
1" (0.08 ft)	19.68" (1.64 ft)	21.10" (1.75 ft)	14.17" (1.18 ft)	9.84" (0.82 ft)	11.81" (0.98 ft)	9.05" (0.75 ft)
1½" (0.13 ft)	23.62" (1.96 ft)	24.96" (2.08 ft)	18.11" (1.50 ft)	11.81" (0.98 ft)	12.20" (1.01 ft)	9.44" (0.78 ft)
2" (0.16 ft)	31.49" (2.62 ft)	32.59" (2.71 ft)	25.19" (2.09 ft)	16.14" (1.34 ft)	12.59" (1.04 ft)	9.84" (0.82 ft)
3" (0.26 ft)	35.43" (2.95 ft)	36.53" (3.04 ft)	27.55" (2.29 ft)	19.29" (1.60 ft)	13.77" (1.14 ft)	11.02" (0.91 ft)
4" (0.32 ft)	44.48" (3.70 ft)	45.51" (3.79 ft)	33.85" (2.82 ft)	25.98" (2.16 ft)	14.56" (1.21 ft)	11.41" (0.95 ft)
6" (0.49 ft)	55.51" (4.62 ft)	57.08" (4.75 ft)	47.24" (3.93 ft)	35.43" (2.95 ft)	15.74" (1.31 ft)	12.99" (1.08 ft)
8" (0.65 ft)	70.86" (5.90 ft)	72.59" (6.04 ft)	57.08" (4.75 ft)	46.06" (3.83 ft)	16.53" (1.37 ft)	13.77" (1.14 ft)

## Specifications

Accuracy	±0.1%, ±0.2% or ±0.5%	
Density Accuracy	0.001 g/cm <sup>3</sup>	
Repeatability	± 0.05% (for 0.1% accuracy), ± 0.1% (for 0.2% accuracy) or ±0.25% (for 0.5% accuracy)	
Sensor Options	U-Series Shaped/Micro-bend Shaped/Triangle Shaped	
Process Media	Liquid, Gas	
Transmitter	Digital type/Analog type	
Power Supply	18-28 VDC, 85-220 VAC	
Maximum Pressure	3770 PSI (26 MPa)	
Signal Output	4-20 mA and Pulse , Optional: HART or Modbus RS485	
Process Connections	DIN, ANSI Flanges	
Electronics	Direct Mount or Remote Mount	
Diagnostic Functions	Reset Totalizer	
Graphic Display	OLED	
Operating Elements	3 optical keys for operator	
Additional Features	Low Flow Cut-off, Oil and Water Content Analysis, Zero Calibration, Flow Calibration, Long-Term Stability, Zero Point Adjustment, Conforms IEC 61362 (Industrial) EMC Directive, Useful for all type of sensors i.e. U-Shaped, Triangle Shaped, Micro-bend Shaped	
Temperature Range	Direct Mount	-58 °F to 257 °F (-50 °C to 125 °C)
	Remote Mount	-58 °F to 392 °F (-50 °C to 200 °C)

## Engineering Units

Program	Units
Mass flow rate	Lb/m, lb/h, kg/m, kg/h, t/h, t/D
Total mass flow	Lb, Kg, T
Volume flow rate	GPM, GPH, M3/m, M3/h, M3/d, Bl/D
Total volume flow	Gal, M3, Bbl
Density	G/ml, Kg/l, Kg/M3, Lb/Gal, g/cm <sup>3</sup> , Lb/f
Temperature	°C, °F
Low flow cut off	Lb/h

Size	Maximum Pressure						
	232 PSI (1.6 MPa)	363 PSI (2.5 MPa)	580 PSI (4.0 MPa)	914 PSI (6.3 MPa)	1450 PSI (10 MPa)	2321 PSI (16 MPa)	3626 PSI (25 MPa)
½" (0.04 ft)	✓	✓	✓	✓	✓	✓	✓
1" (0.08 ft)	✓	✓	✓	✓	✓	✓	—
1½" (0.13 ft)	✓	✓	✓	✓	✓	—	—
2" (0.16 ft)	✓	✓	✓	✓	✓	—	—
3" (0.26 ft)	✓	✓	✓	✓	—	—	—
4" (0.32 ft)	✓	✓	✓	✓	—	—	—
6" (0.49 ft)	✓	✓	✓	—	—	—	—
8" (0.65 ft)	✓	✓	✓	—	—	—	—

## Flow Ranges

### Flow Range for liquid (U-Shaped)

Size (Inch)	Allowable Flow Range (lb/h)	Normal Flow Range for Accuracy 0.1% (lb/h)	Normal Flow Range for Accuracy 0.2%, 0.5% (lb/h)
1½"	706 – 70547	4410 – 70547	3307 – 70547
2"	1103 – 110231	6614 – 110231	5512 – 110231
3"	3087 – 308647	13228 – 308647	12126 – 308647
4"	4410 – 440924	33070 – 440924	26456 – 440924
6"	11024 – 1102311	77162 – 1102311	66139 – 1102311
8"	22047 – 2204622	154324 – 2204622	154324 – 2204622

### Flow Range for liquid (Micro-bend Shaped)

Size (Inch)	Allowable Flow Range (lb/h)	Normal Flow Range for Accuracy 0.1% (lb/h)	Normal Flow Range for Accuracy 0.2%, 0.5% (lb/h)
½"	45 – 6613	441 – 6613	331 – 6613
1"	177 – 17636	1323 – 17636	882 – 17636
1½"	530 – 52910	5292 – 52910	2646 – 52910
2"	1103 – 110231	11024 – 110231	5512 – 110231
3"	1764 – 264554	17631 – 264554	17637 – 264554
4"	3307 – 440924	33070 – 440924	22047 – 440924
6"	11024 – 1102311	110232 – 1102311	55116 – 1102311
8"	22047 – 2204622	220463 – 2204622	1102312 – 2204622



## Flow Range for Gas

Size (Inch)	Measurable Flow Range (lb/h)	Flow Range with 0.5% (lb/h)
½"	34 – 6613	166 – 6613
1"	89 – 17636	445 – 17635
1½"	706 – 70547	1770 – 70545
2"	1103 – 110231	2760 – 110230
3"	1544 – 308647	7720 – 308647
4"	2205 – 440924	11025 – 440924
6"	5512 – 1102311	27560 – 1102311

## Installation

### Micro-bend Shaped installation

For Liquid or Slurry

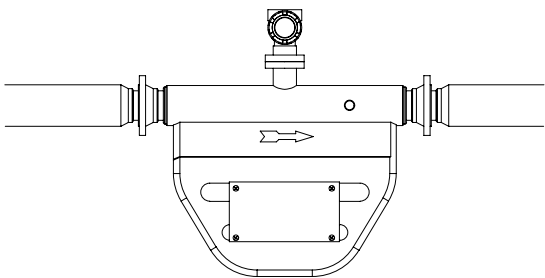

Picture-1

For Gas

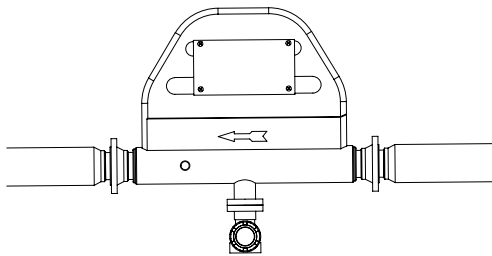

Picture-2

For Liquid, Slurry, or Gas

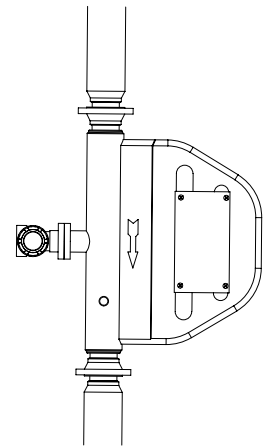

Picture-3

## U-Shaped Installation

For Liquid or Slurry

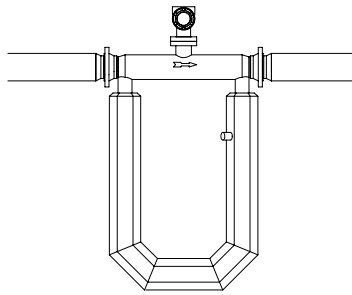

Picture-1

For Gas

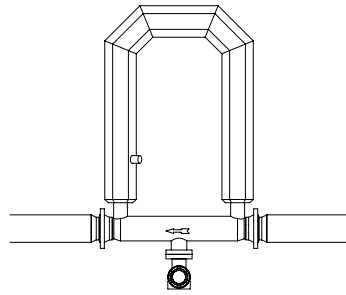

Picture-2

For Liquid, Slurry, or Gas

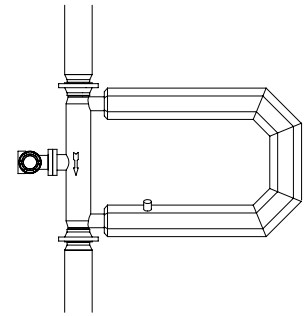

Picture-3

For the horizontal installation, the measuring tube should be installed downside of the pipeline when the process medium is liquid or slurry (shown in Picture 1) and upside of the pipeline when the process medium is gas (shown in Picture 2). For vertical installation, the measuring tube should be installed beside the pipeline when the process medium is liquid, slurry, or gas (shown in Picture 3).

If gas bubbles are expected, the meters must not be mounted at the highest point of the tubing (A). If solid particles are expected the meters must not be mounted at the lowest point (B) of the pipeline. The meters must not be mounted in a drop line near the open end (C), as this can cause the meters to run empty.

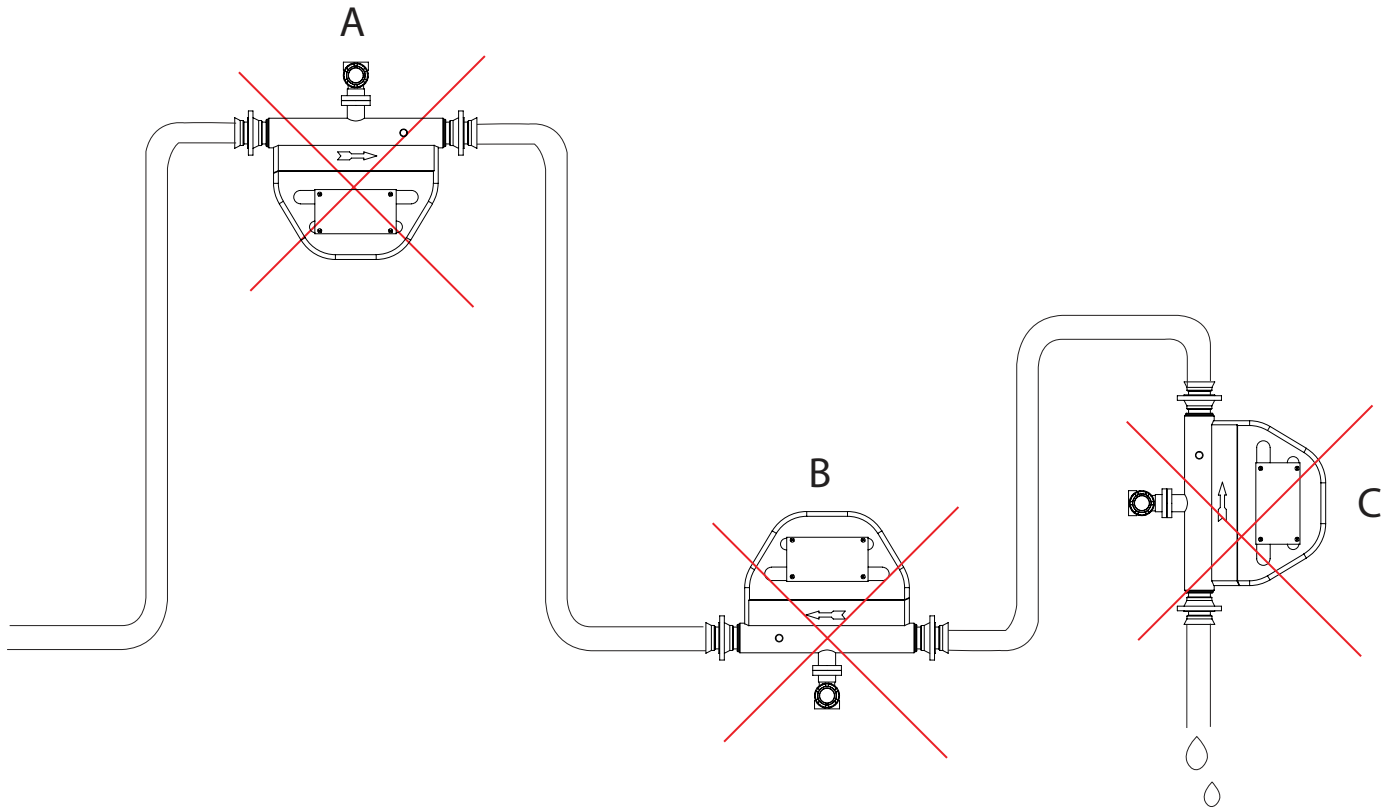

# Model Chart

<b>EXAMPLE</b>	<b>Tek-Cor 1100A</b>	<b>2</b>	<b>1</b>	<b>025B</b>	<b>1</b>	<b>S</b>	<b>150</b>	<b>1</b>	<b>E</b>	<b>Tek-Cor 1100A-2-1-025B-1-S-150-1-E</b>
<b>Series</b>	Tek-Cor 1100A									Coriolis Mass Flow Meter
<b>Type</b>		1 2 3								U-Shaped Micro-bend Shaped Triangle Shaped
<b>Process Media</b>			1							Liquid or Gas
<b>Size and Accuracy</b>				015A 025A 040A 050A 080A 100A 150A 200A 015B 025B 040B 050B 080B 100B 150B 200B 015C 025C 040C 050C 080C 100C 150C 200C						½", ± 0.5% Accuracy (M and T type only) 1", ± 0.5% Accuracy (M and T type only) 1-½", ± 0.5% Accuracy (M and U type only) 2", ± 0.5% Accuracy (M and U type only) 3", ± 0.5% Accuracy (M and U type only) 4", ± 0.5% Accuracy (M and U type only) 6", ± 0.5% Accuracy (M and U type only) 8", ± 0.5% Accuracy (M and U type only) ½", ± 0.2% Accuracy (M and T type only) 1", ± 0.2% Accuracy (M and T type only) 1-½", ± 0.2% Accuracy (M and U type only) 2", ± 0.2% Accuracy (M and U type only) 3", ± 0.2% Accuracy (M and U type only) 4", ± 0.2% Accuracy (M and U type only) 6", ± 0.2% Accuracy (M and U type only) 8", ± 0.2% Accuracy (M and U type only) ½", ± 0.1% Accuracy (M and T type only) 1", ± 0.1% Accuracy (M and T type only) 1-½", ± 0.1% Accuracy (M and U type only) 2", ± 0.1% Accuracy (M and U type only) 3", ± 0.1% Accuracy (M and U type only) 4", ± 0.1% Accuracy (M and U type only) 6", ± 0.1% Accuracy (M and U type only) 8", ± 0.1% Accuracy (M and U type only)
<b>Electronics</b>					1 2					Direct Mount Remote Mount (comes with 10 meters of cable)
<b>Output</b>						I S				4-20 mA, HART, Pulse 4-20 mA, Modbus RS485, Pulse
<b>Process Connection</b>							025 040 100 160 260 150 300 600			DIN 2.5 MPa Flange DIN 4 MPa Flange DIN 10 MPa Flange DIN 16 MPa Flange DIN 26 MPa Flange 150# ANSI Flange 300# ANSI Flange 600# ANSI Flange
<b>Power Supply</b>								1 2		18-28 VDC 85-220 VAC
<b>Approvals</b>									E	UL Class I Div. I

## Popular Models

MODEL NO.	DESCRIPTION
1100A-2-1-015A-1-S-150-1-E	Explosion-proof ½", 0.5%, 150# ANSI Flange
1100A-2-1-025A-1-S-150-1-E	Explosion-proof 1", 0.5%, 150# ANSI Flange
1100A-2-1-040A-1-S-150-1-E	Explosion-proof 1.5", 0.5%, 150# ANSI Flange
1100A-2-1-050A-1-S-150-1-E	Explosion-proof 2", 0.5%, 150# ANSI Flange
1100A-2-1-080A-1-S-150-1-E	Explosion-proof 3", 0.5%, 150# ANSI Flange
1100A-2-1-015B-1-S-150-1-E	Explosion-proof ½", 0.2%, 150# ANSI Flange
1100A-2-1-025B-1-S-150-1-E	Explosion-proof 1", 0.2%, 150# ANSI Flange
1100A-2-1-040B-1-S-150-1-E	Explosion-proof 1.5", 0.2%, 150# ANSI Flange
1100A-2-1-050B-1-S-150-1-E	Explosion-proof 2", 0.2%, 150# ANSI Flange
1100A-2-1-080B-1-S-150-1-E	Explosion-proof 3", 0.2%, 150# ANSI Flange

# Customer Service and Support



TEKMATION LLC reserves the right to change the designs and/or materials of its products without notice. The contents of this publication are the property of TEKMATON and cannot be reproduced by any other party without written permission. All rights reserved. Copyright © 2016 TEKMATON LLC  
DOC # TEK/MR/190124/TEK-COR/G  
TEKMATION LLC



[www.tek-trol.com](http://www.tek-trol.com)

Tek-Trol is a fully owned subsidiary of TEKMATON LLC. We offer our customers a comprehensive range of products and solutions for process, power, and oil and gas industries. Tek-Trol provides process measurement and control products for Flow, Level, Temperature and Pressure Measurement, Control Valves and Analyzer systems. We are present in 15 locations globally and are known for our knowledge, innovative solutions, reliable products, and global presence.

## **Tek-Trol LLC**

796 Tek Drive Crystal Lake, IL 60014 USA  
Tel: +1 847 857 6076, +1 847 655 7428 Fax: +1 847 655 6147  
Email: [tektrol@tek-trol.com](mailto:tektrol@tek-trol.com)  
[www.tek-trol.com](http://www.tek-trol.com)